

A kitchen scene where the ceiling is made of horizontal wooden planks and the wall is made of vertical green planks. A wooden shelf is mounted on the ceiling, holding three black pots with wooden handles. Below the shelf, a stainless steel pot is boiling on a black induction cooktop, with steam rising from it. The cooktop is on a white marble countertop above wooden cabinets.

SWITCH YOUR KITCHEN  
UPSIDE DOWN

PMF

 elica  
aria nuova



A photograph of a modern interior space. A large window with a dark wooden frame is the central focus. To the left, a tree with vibrant autumn foliage in shades of yellow, orange, and red is visible. The room features light-colored walls and a ceiling. On the right, a portion of a white built-in cabinet or wall unit is visible. The overall atmosphere is bright and minimalist.

BUILT-IN



# HIDDEN

ELICA DESIGN CENTER



## TEHNIČNI PODATKI TECHNICAL FEATURES

Velikost Size	60 - 90 cm
Izvedba Version	Odzračevalna Duct out
Videz Finish	Nerjavno jeklo, Nerjavno jeklo + Belo steklo Stainless steel, Stainless steel + white glass

### OSVETLITEV LIGHTING

Tipi Type	STRIPE LED 1 x 7 W
Intenzivna moč Intensity	147 LUX
Temperature Temperature	4000 K

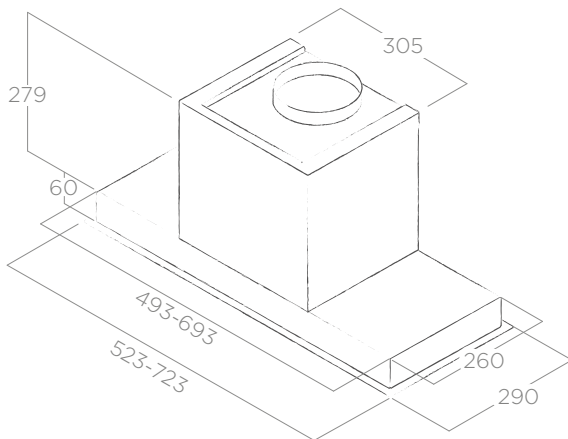

## OBLIKA PERFORMANCE

Upravljanje Controls	3 Hitrosti + B na dotik 3S+B Touch Control
Pretok zraka Booster airflow	600 m <sup>3</sup> /h
Raven hrupa Noise level	65 db(A)
Popolna absorpcija Total absorption	262 W
Izhod Duct size	150 mm
Razred energetske učinkovitosti Energy class	B (A <sup>++</sup> /E)

Z aluminijastim mazalnim filtrom Grease aluminium filter included

### DODATKI ACCESSORIES

Ogleni filter Charcoal filter	CFC0140343
Komplet dimnik teleskopski h18,5+h18,5 Telescopic chimney kit h18,5+h18,5	KIT0141458

### MODELI MODELS

HIDDEN IX/A/60	PRF0092333
HIDDEN IX/A/90	PRF0095073
HIDDEN IXGL/A/60	PRF0097676
HIDDEN IXGL/A/90	PRF0097708





# BOXIN PLUS

ELICA DESIGN CENTER



## TEHNIČNI PODATKI TECHNICAL FEATURES

Velikost Size	60 - 90 - 120 cm
Izvedba Version	Odzračevalna Duct out
Videz Finish	Nerjavno jeklo + Belo steklo Stainless steel + white glass

### OSVETLITEV LIGHTING

Tipi Type	LED 2 x 2,5 W
Intenzivna moč Intensity	145 LUX
Temperature Temperature	4000 K

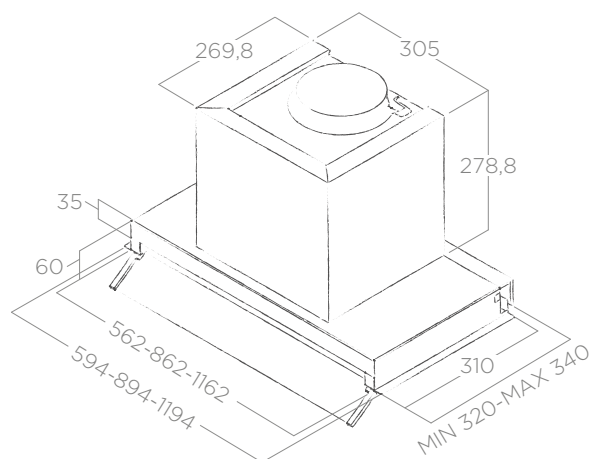

## OBLIKA PERFORMANCE

Upravljanje Controls	3 Hitrosti vrtljiv gumb 3S Rotative
Maksimalni pretok zraka max airflow	645 m <sup>3</sup> /h
Raven hrupa Noise level	68 db(A)
Popolna absorpcija Total absorption	260 W
Izhod Duct size	150 mm
Razred energetske učinkovitosti Energy class	B (A <sup>++</sup> /E)

Z aluminijastim mazalnim filtrom Grease aluminium filter included

### DODATKI ACCESSORIES

Ogleni filter Charcoal Filter	CFC0140343
Komplet dimnik H12 Chimney kit h12	KIT0091876
Komplet dimnik teleskopski h18,5+h18,5 Telescopic chimney kit h18,5+h18,5	KIT0141458

### MODELI MODELS

BOX IN PLUS IXGL/A/60	PRF0097795
BOX IN PLUS IXGL/A/90	PRF0097796
BOX IN PLUS IXGL/A/120	PRF0097797







Ekskluzivni zastopnik za Slovenijo:

**PMF d.o.o.**  
Letališka cesta 3c  
1000 Ljubljana

Tel: 01 513 51 64  
Fax: 01 513 52 08  
E-pošta: [elica@pmf.si](mailto:elica@pmf.si)  
[www.pmf.si](http://www.pmf.si)

